





Drive Pinion Flange and Drive Pinion Seal

Special Tool(s)

 <p>ST2026-A</p>	2 Jaw Puller 205-D072 (D97L-4221-A) or equivalent
 <p>ST1257-A</p>	Holding Fixture, Drive Pinion Flange 205-126 (T78P-4851-A)
	Installer, Drive Pinion Flange 205-002 (TOOL-4858-E)
 <p>ST1325-A</p>	Installer, Drive Pinion Oil Seal 205-208 (T83T-4676-A)

Material

Item	Specification
Motorcraft® SAE 75W-140 Synthetic Rear Axle Lubricant XY-75W140-QL (US); CXY- 75W140-1L (Canada)	WSL-M2C192-A and GL-5
Premium Long-Life Grease XG-1-C or XG-1-K (US); CXG-1-C (Canada)	ESA-M1C75-B

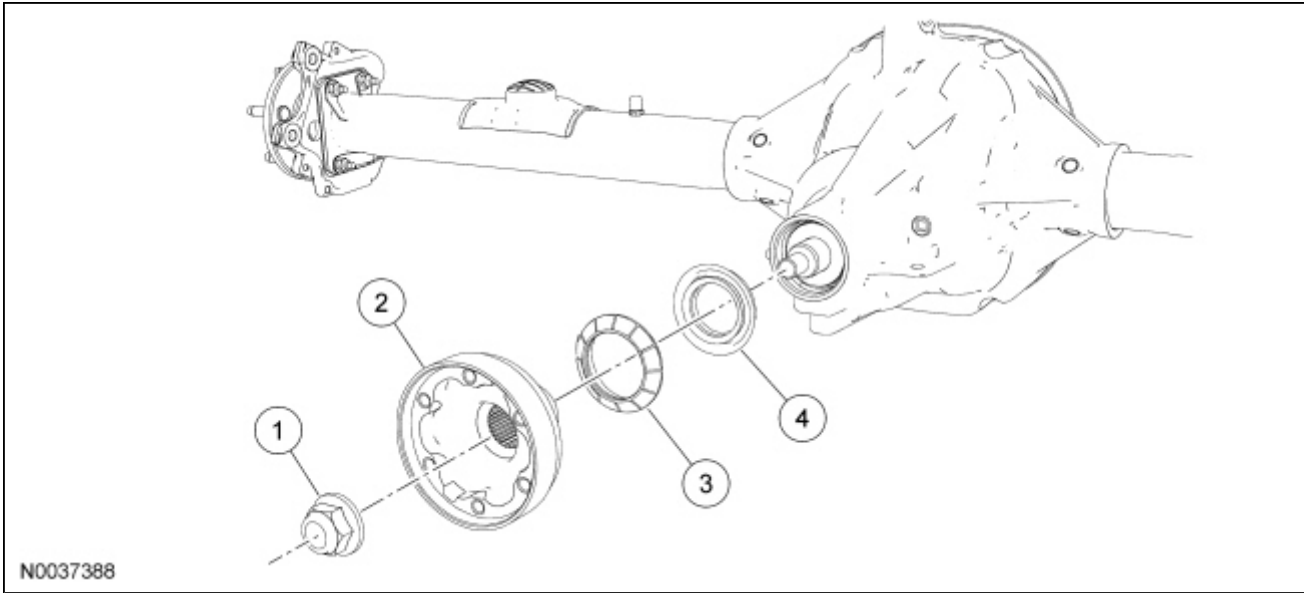

Item	Part Number	Description
1	389546-S100	Pinion nut
2	4851	Pinion flange
3	4859	Deflector
4	4676	Drive pinion seal

Removal

NOTICE: This operation disturbs the pinion bearing preload. Install a new pinion nut with the same color as the original if not replacing the collapsible spacer. If a new collapsible spacer is installed, install the pinion nut in the kit or damage to the component may occur.

1. With the vehicle in NEUTRAL, position it on a hoist. For additional information, refer to [Section 100-02](#).
2. Remove the driveshaft. For additional information, refer to [Section 205-01](#).
3. **NOTE:** The disc brake calipers must be removed to prevent brake drag during drive pinion bearing preload adjustment.

Remove the rear brake disc. For additional information, refer to [Section 206-04](#).

4. Using a Nm (lb-in) torque wrench on the pinion nut, record the torque required to maintain rotation of the pinion gear through several revolutions.

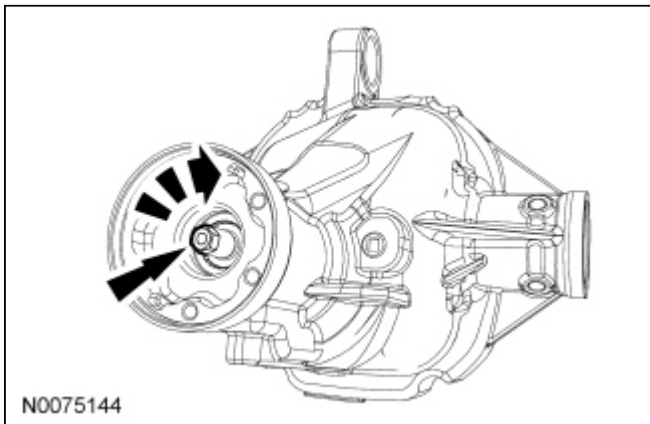

- Using the Drive Pinion Flange Holding Fixture to hold the pinion flange, remove and discard the pinion nut.

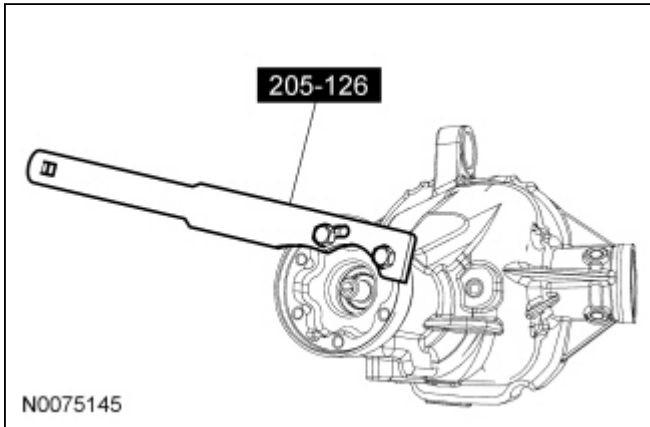

- Index-mark the pinion flange in relation to the drive pinion stem to make sure of correct alignment during installation.

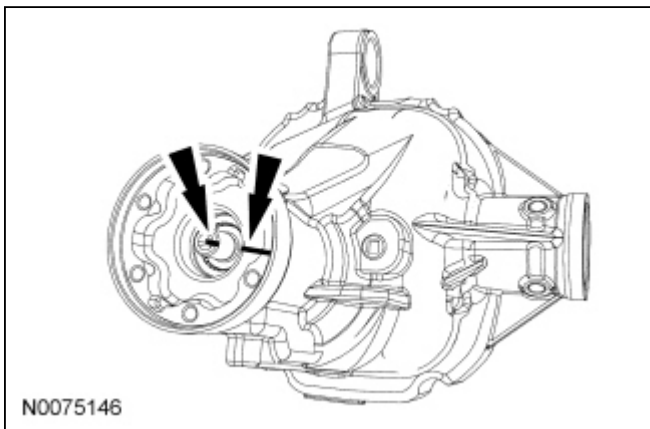

- Using the 2 Jaw Puller, remove the pinion flange.

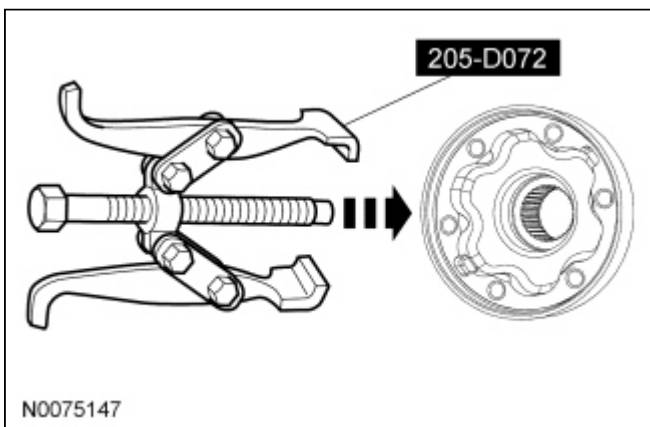

- Force up on the metal flange of the drive pinion seal. Install gripping pliers and strike with a hammer until the drive pinion seal is removed.

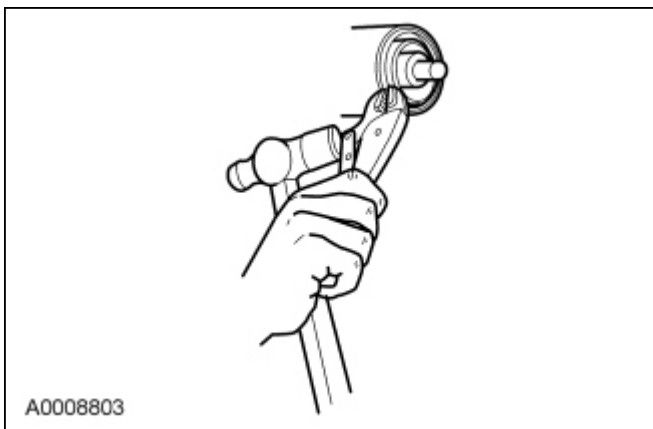

Installation

1. Lubricate the new drive pinion seal with grease.
2. **NOTE:** If the new drive pinion seal becomes misaligned during installation, remove the drive pinion seal and install a new drive pinion seal.

Using the Drive Pinion Oil Seal Installer, install a new drive pinion seal.

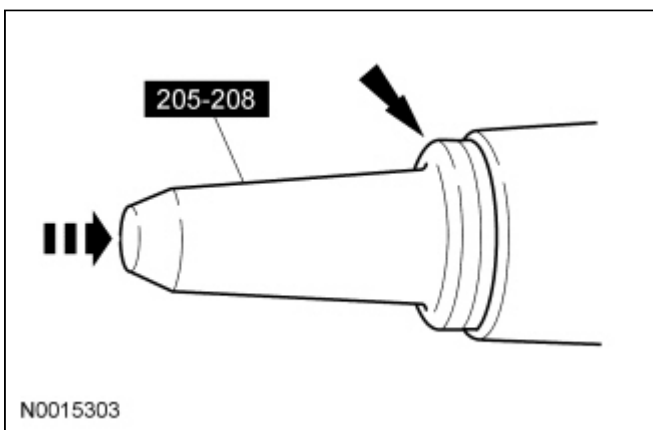

3. Lubricate the pinion flange splines with axle lubricant.
4. **NOTE:** Disregard the scribe marks if a new pinion flange is being installed.

Align the pinion flange with the drive pinion shaft.

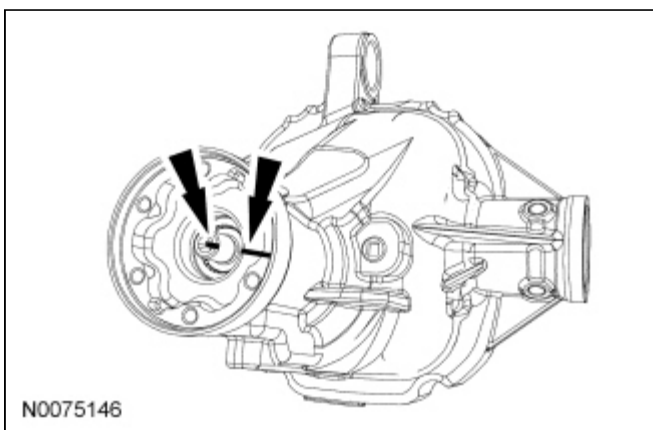

- Using the Drive Pinion Flange Installer, install the pinion flange.

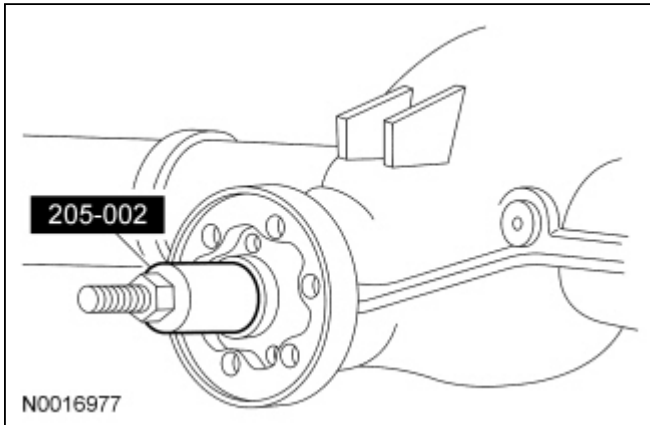

- Position the new pinion nut.
- NOTE:** Under no circumstances is the pinion nut to be backed off to reduce drive pinion bearing preload. If reduced drive pinion bearing preload is required, a new drive pinion collapsible spacer and pinion nut kit must be installed.

NOTE: Remove the Drive Pinion Flange Holding Fixture while taking drive pinion bearing preload readings with the Nm (lb-in) torque wrench.

Using the Drive Pinion Flange Holding Fixture to hold the pinion flange, tighten the pinion nut.

- Rotate the drive pinion occasionally to make sure the drive pinion bearings are seating correctly.
- Install a Nm (lb-in) torque wrench on the pinion nut.
- Rotating the drive pinion through several revolutions, take frequent drive pinion bearing preload readings until the original recorded drive pinion bearing preload reading is obtained.
- If the original recorded drive pinion bearing preload is lower than specifications, tighten to the specification. If the drive pinion bearing preload is higher than specification, tighten the pinion nut to the original reading as recorded. For additional information, refer to the Specifications portion of this section.

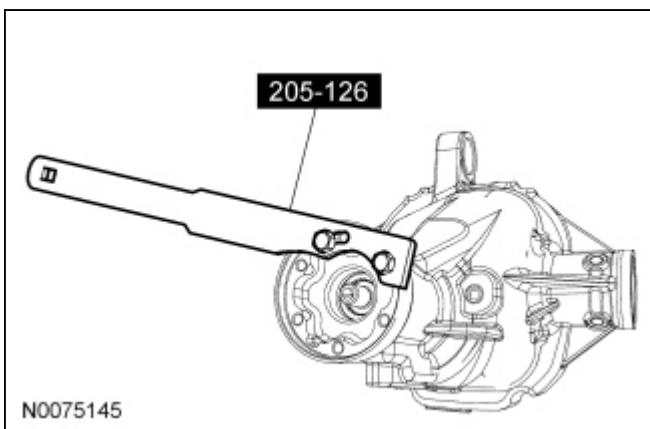

- Install the driveshaft. For additional information, refer to [Section 205-01](#).
 - Install the rear brake disc. For additional information, refer to [Section 206-04](#).
-

